



KITS



PUMPS



METERS



METERED NOZZLES



NOZZLES



WASTE OIL EQUIPMENTS

# MA 130

## FEATURES

- IN/OUT INTERCHANGEABLE
- LONG LIFE DIAPHRAGM
- BUILT-IN DIFFUSER
- SUITABLE FOR IMMERSED INSTALLATIONS
- HEAVY DUTY
- EXPLOSION PROOF (EX ZONE 2)
- STURDY DESIGN

The PIUSI MA130 is a pneumatic diaphragm pump suitable for transferring high viscosity fluids and waste oils. Thanks to its small size this pumps is easy to fit in any working environment.

### PERFORMANCE

UP TO  
**90 L/MIN**

FLOW RATE

MAX  
**7 BAR**

AIR PRESSURE

MAX CAPACITY  
**5 M**

SELF PRIMING

MAX  
**Ø 4MM**

PASSING SOLID



MA 130



### PACKAGING

CODE	WEIGHT		PACKAGING			
	KG	LBS	MM	INCH	PCS/PALLET	PCS/BOX
FOO208A00	4	8,8	220X310X320	8,7X12,2X12,6		1



FILTRATION



FLUID MONITORING



TANK MONITORING



HOSE REELS



ACCESSORIES



MERCHANDISE

INDEX



AIR



ANTIFREEZE



AdBlue®



BIODIESEL



DIESEL



FOOD



GASOLINE



GREASE



KEROSENE



OIL



WATER



WINDSCREEN

### CHART

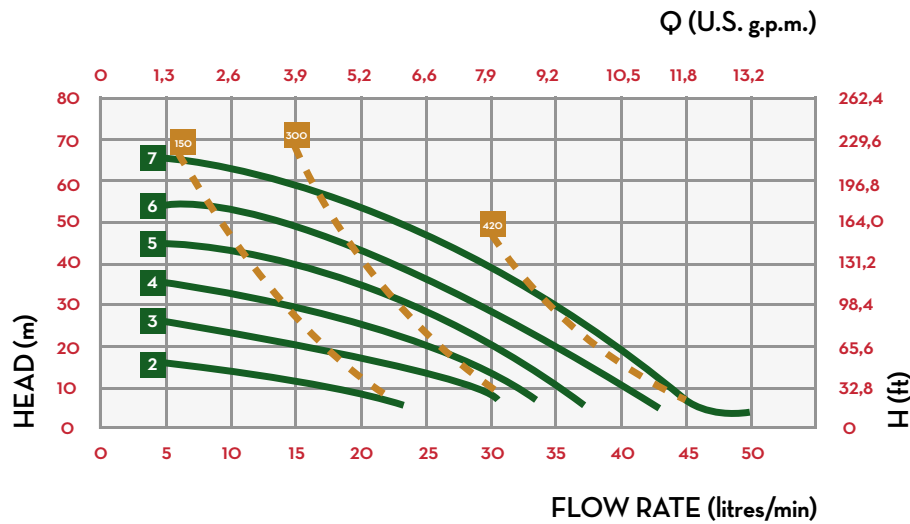

### IN THE BOX

- MA 130 PUMP
- INSTRUCTION MANUAL

### DETAILS



HEAVY DUTY MATERIALS



TECHNOPOLYMER BODY



EASY TO FIT

### MATERIALS

- BODY: TECHNOPOLYMER
- FITTINGS: ALLUMINIUM
- DIAPHRAGMS: TECHNOPOLYMER

### DIMENSIONS

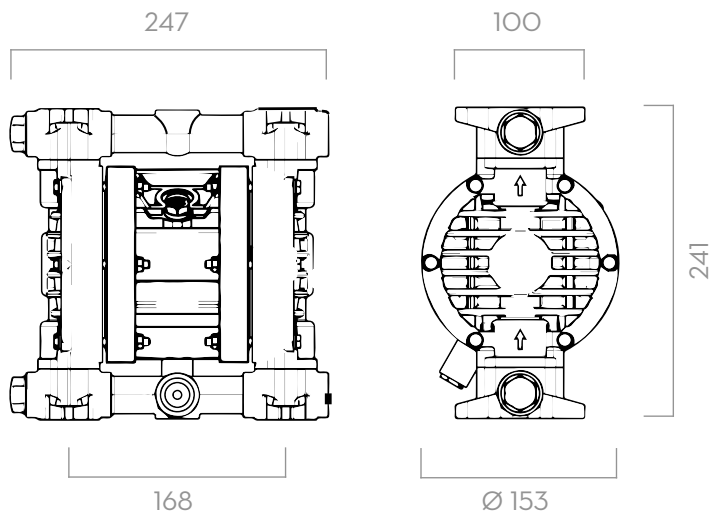

Dimensions expressed in millimeters

### TECHNICAL DATA

CODE	DESCRIPTION	FLUIDS TYPE	PUMP BODY	IN / OUT	FLOW RATE L/MIN	MEMBRANE TYPE	DIAPHRAGM	BALLS	BALL SEATS*	O-RING*	INTAKE / DELIVERY CONNECTION	AIR CON-NECTION	MAX SELF-PRIMING CAPACITY	MAX HEAD**	MAX AIR SUP-PLY PRESSURE	MAX Ø OF PASSING SOLID
													M	M	BAR	MM
FOO208A00	PIUSI MA 130		ALLUMINIUM	1/2" G	50	SINGLE	NBR	NBR	ALLUMINIUM	NBR	G 1/2" F	G 3/8" F	5	70	7	4

(\*) ON REQUEST WE CAN PROVIDE MEMBRANES, BALLS, BALL SEATS AND O-RINGS IN DIFFERENT MATERIALS.

(\*\*) THE VALUE DEPENDS ON THE CONFIGURATION OF THE PUMP

# MA 130